

UNION PACIFIC RAILROAD COMPANY



PERISHABLE AND MANIFEST TRAIN SCHEDULES

SCHEDULE NO. 22

—
Effective
September 1, 1970
—

J. BOWEN

General Superintendent Transportation
Omaha, Nebraska

Provided by
www.uphs.org



CHICAGO – ST. LOUIS – MEMPHIS – DECATUR TO LOS ANGELES – SAN FRANCISCO – PORTLAND – SPOKANE – SEATTLE

	ALAF	LAF	LAM	AFMS	FMS	WCM	ASLF WMX	SLF AP	SLM PBF	KLS CLS ①	NWH ANWF	NWF	NWM
ChicagoCT...(C&NW) ... Lv. (IC) Lv. (CRIP) Lv. (MILW) Lv. (BN) Lv.	2:00am (1) 3:00pm (0) 3:30am (1)	10:00am (1) 8:00am (1) 11:00am (1) 11:00am (1)		3:00pm (0) 9:00am (1)	10:00am (1) 8:00am (1) 11:00am (1) 11:00am (1)		2:00am (1) 3:00pm (0) 3:30am (1)	10:00am (1) 8:00am (1) 11:00am (1) 11:00am (1)			2:00am (1) 3:00pm (0) 3:30am (1)	10:00am (1) 8:00am (1) 11:00am (1) 11:00am (1)	3:30pm (0)
DecaturCT...(N&W) ... Lv.		4:30am (1)	1:30pm (0)		4:30am (1)	1:30pm (0)		4:30am (1)	1:30pm (0)			4:30am (1)	1:30pm (0)
St. LouisCT...(N&W) ... Lv.			8:30pm (0)			8:30pm (0)			8:30pm (0)				8:30pm (0)
MemphisCT...(SLSF) ... Lv. (MP) Lv.	9:30pm (0)	10:30pm (0)			10:30pm (0)		9:30pm (0)				9:30pm (0)	10:30pm (0)	
Kansas CityCT...(N&W) ... Lv. (SLSF) Lv. (MP) Lv. (YARD) Lv.	2:30pm (1) 11:00am (1)	5:30pm (1) 7:00pm (1)	5:30am (1) 5:30am (1)	11:00am (1)	5:30pm (1) 7:00pm (1)	5:30am (1) 5:30am (1)	2:30pm (1) 11:00am (1)	5:30pm (1) 7:00pm (1)	5:30am (1) 5:30am (1)	7:00pm (0)	2:30pm (1) 11:00am (1)	5:30pm (1) 7:00pm (1)	5:30am (1) 5:30am (1)
Council BluffsCT...(YARD) ... Lv. (IC) Lv. (CRIP) Lv. (MILW) Lv.	2:00pm (1) 2:00pm (1)	10:30pm (1) 11:00pm (1)	6:00am (1)	2:00pm (1) 2:00pm (1)	10:30pm (1) 11:00pm (1)	6:00am (1)	2:00pm (1) 2:00pm (1)	10:30pm (1) 11:00pm (1)	6:00am (1)	1:00am (1)	2:00pm (1) 2:00pm (1)	10:30pm (1) 11:00pm (1)	6:00am (1)
FremontCT...(C&NW) ... Lv.	6:30pm (1)	11:30pm (1)			11:30pm (1)		6:30pm (1)	11:30pm (1)		2:30am (1)	6:30pm (1)	11:30pm (1)	
Grand IslandCT...(BN) Lv.	10:35pm (1)	4:05am (2)		9:20pm (1)	4:05am (2)		10:35pm (1)	4:05am (2)		4:45am (1)	10:35pm (1)	4:05am (2)	
North PlatteMT Lv.	3:00am (2)	7:00am (2)	3:00pm (1)	12:15am (2)	8:00am (2)	3:00pm (1)	4:00am (2)	8:00am (2)	3:00pm (1)	8:00am (1)	3:00am (2)	8:00am (2)	6:00pm (1)
CheyenneMT Lv.	7:40am (2)	11:40am (2)	7:40pm (1)	4:45am (2)	12:40pm (2)	7:40pm (1)	8:40am (2)	12:40pm (2)	7:40pm (1)	12:40pm (1)	7:40am (2)	12:30pm (2)	12:25am (2)
Green RiverMT Lv.	3:20pm (2)	7:20pm (2)	3:20am (2)	11:55am (2)	8:20pm (2)	3:20am (2)	4:20pm (2)	8:20pm (2)	3:20am (2)	8:20pm (1)	3:20pm (2)	7:40pm (2)	11:15am (2)
OgdenMT Ar. Lv. (SP) Lv.				4:45pm (2) 5:00pm (2)	1:15am (3) 1:30am (3)	8:15am (2) 8:30am (2)	9:00pm (2) 9:05pm (2)	1:00am (3) 1:05am (3)	8:00am (2) 8:05am (2)				
Salt LakeMT Ar. Lv. (WP) Lv.	10:00pm (2)	2:00am (3)	12:01pm (2)				10:30pm (2) 2:00am (3)	2:30am (3) 10:00am (3)	9:30am (2) 9:00pm (2)	6:00am (2)			
ColtonPT Lv.	4:45pm (3)	8:45pm (3)	2:20pm (3)										
Los AngelesPT Ar.	6:30pm (3)	10:30pm (3)	5:30pm (3)							4:00am (3)			
San FranciscoPT Ar.				11:59am (3)	11:59pm (3)	6:00am (3)	5:00am (4)	6:00pm (4)	10:30pm (3)				
PocatelloMT Lv.											9:40pm (2)	2:10am (3)	6:00pm (2)
HinklePT Lv.											10:55am (3)	1:20pm (3)	8:55am (3)
PortlandPT Ar. Lv.											4:00pm (3) 4:30pm (3)	6:00pm (3) 6:30pm (3)	3:00pm (3) 4:30pm (3)
SpokanePT Ar.											8:00pm (3)		8:00pm (3)
SeattlePT Ar.											10:00pm (3)	11:00pm (3)	10:00pm (3)

KANSAS CITY

DENVER

GREEN RIVER

OGDEN

SALT LAKE

LOS ANGELES

NORTH PLATTE (BAILEY YARD)

COUNCIL BLUFFS

FREMONT

GRAND ISLAND

POCATELLO

NAMPA

HINKLE

PORTLAND

SEATTLE

SPOKANE

OFFICE OF GENERAL SUPERINTENDENT OF TRANSPORTATION SCHEDULE CONTROL OMAHA, NEBRASKA SEPTEMBER 1, 1970

◆ - INDICATES CONNECTIONS
A - AM
P - PM
- DP CONNECTS WITH NWM AT GREEN RIVER
- ADP CONNECTS WITH NPP AT GREEN RIVER

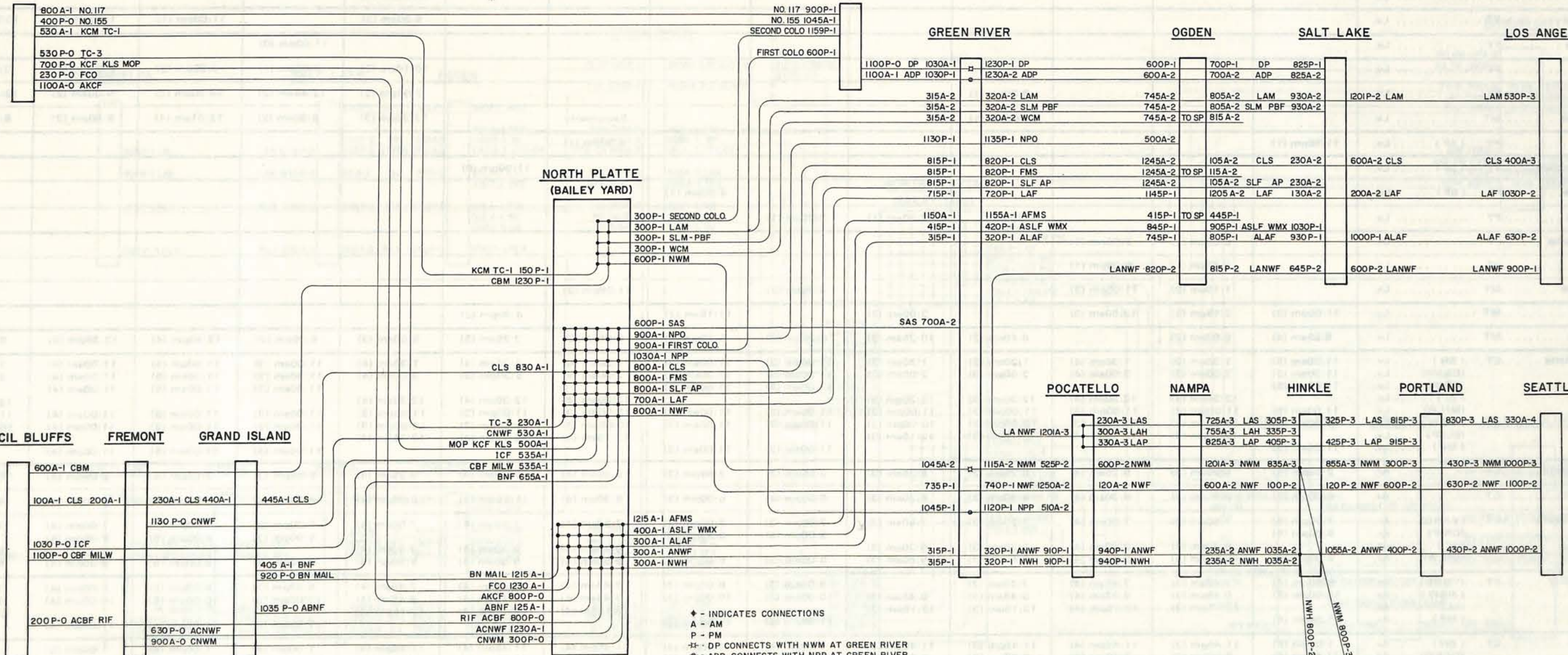

PACIFIC COAST TO CHICAGO – ST. LOUIS – MEMPHIS – DENVER

	OS	LAX	UTX-CN	PNF	BAX (SP)	CIX (WP)	RV ²	WP	OVE	SPX	HF	NPX	WX	HFD
SeattlePT Lv.										10:00pm (1)				
PortlandPT Lv.										5:30am (2)		11:00pm (1)	1:00pm (1)	10:00pm (1)
SpokanePT Lv.											11:00pm (0)			
HinklePT Lv.										10:10am (2)	3:00pm (1)	3:30pm (2)	8:00pm (1)	3:00am (2)
NampaPT Lv.				3:30am (1)						7:00pm (2)	12:45am (2)	10:00am (3)	9:00am (2)	12:45pm (2)
PocatelloMT Lv.				4:00pm (1)				Sacramento		12:30am (3)	8:30am (2)	12:01am (4)	9:00pm (2)	8:30pm (2)
EugenePT...(SP) Lv.	11:59pm (1)							4:30pm (1)						
San FranciscoPT...(SP) Lv.									11:00pm (0)					
RosevillePT...(SP) Lv.							4:30pm (1)							
OaklandPT Lv.					2:30am (1)	2:00am (1)								
Los AngelesPT Lv.		6:00am (1)	5:00pm (1)											
ColtonPT Lv.		7:40am (1)	9:00pm (1)											
Salt LakeMT Lv.		1:10am (2)	11:05pm (2)			8:30am (2)		11:05pm (2)						
OgdenMT Lv.	11:00pm (3)	2:15am (2)	12:50am (3)		3:00am (2)		11:15am (2)		4:30pm (2)					
RawlinsMT Lv.	8:55am (4)	9:00am (2)		6:40am (2)	10:25am (2)	6:25pm (2)	6:25pm (2)	9:05am (3)	3:25am (3)	9:00am (3)	6:00pm (2)	12:40pm (4)	12:35pm (3)	6:00am (3)
North PlatteCT...(BN) Lv.	11:00am (5)	1:30am (3)	1:30am (4)	1:30am (3)	1:30am (3)	11:00am (3)	11:00am (3)	1:30am (4)	1:30am (4)	1:30am (4)	11:00am (3)	11:00am (5)	11:00am (4)	1:30am (4)
(C&NW) Lv.	11:30am (5)	2:00am (3)	2:00am (4)	2:00am (3)	2:00am (3)	11:30am (3)	11:30am (3)	2:00am (4)	5:30pm (3)	2:00am (4)	11:30am (3)	11:30am (5)	11:30am (4)	2:00am (4)
(CRIP) Lv.	11:00am (5)					11:00am (3)	11:00am (3)				11:00am (3)	11:00am (5)	11:00am (4)	
(IC) Lv.		12:30am (3)	12:30am (4)	12:30am (3)	12:30am (3)			12:30am (4)	12:30am (4)	12:30am (4)				12:30am (4)
(MILW) Lv.	11:00am (5)	11:00pm (2)	11:00pm (3)	11:00pm (2)	11:00pm (2)	11:00am (3)	11:00am (3)	11:00pm (3)	11:00pm (3)	11:00pm (3)	11:00am (3)	11:00am (5)	11:00am (4)	11:00pm (3)
(N&W) Lv.	11:00am (5)	10:00pm (2)	10:00pm (3)	10:00pm (2)	10:00pm (2)	11:00am (3)	11:00am (3)	10:00pm (3)	10:00pm (3)	10:00pm (3)	11:00am (3)	11:00am (5)	11:00am (4)	10:00pm (3)
(SLSF) Lv.		12:15am (3)	12:15am (4)	12:15am (3)	12:15am (3)			12:15am (4)	12:15am (4)	12:15am (4)				12:15am (4)
(MP) Lv.	11:00am (5)					11:00am (3)	11:00am (3)				11:00am (3)	11:00am (5)	11:00am (4)	
Grand IslandCT Ar.	2:55pm (5)	5:25am (3)	5:25am (4)	5:25am (3)	5:25am (3)	2:55pm (3)	2:55pm (3)	5:25am (4)	5:25am (4)	5:25am (4)	2:55pm (3)	2:55pm (5)	2:55pm (4)	5:25am (4)
FremontCT Ar.	6:00pm (5)	8:30am (3)	8:30am (4)	8:30am (3)	8:30am (3)	6:00pm (3)	6:00pm (3)	8:30am (4)	11:59pm (3)	8:30am (4)	6:00pm (3)	6:00pm (5)	6:00pm (4)	8:30am (4)
Council BluffsCT...(YARD) Ar.	7:00pm (5)	7:50am (3)	7:50am (4)	7:50am (3)	7:50am (3)	7:00pm (3)	7:00pm (3)	7:50am (4)	7:50am (4)	7:50am (4)	7:00pm (3)	7:00pm (5)	7:00pm (4)	7:50am (4)
(CRIP) Ar.	8:00pm (5)					8:00pm (3)	8:00pm (3)				8:00pm (3)	8:00pm (5)	8:00pm (4)	
(IC) Ar.		9:30am (3)	9:30am (4)	9:30am (3)	9:30am (3)			9:30am (4)	9:30am (4)	9:30am (4)				9:30am (4)
(MILW) Ar.	8:00pm (5)	9:50am (3)	9:50am (4)	9:50am (3)	9:50am (3)	8:00pm (3)	8:00pm (3)	9:50am (4)	9:50am (4)	9:50am (4)	8:00pm (3)	8:00pm (5)	8:00pm (4)	9:50am (4)
Kansas CityCT...(YARD) Ar.	8:00pm (5)	7:45am (3)	7:45am (4)	7:45am (3)	7:45am (3)	8:00pm (3)	8:00pm (3)	7:45am (4)	7:45am (4)	7:45am (4)	8:00pm (3)	8:00pm (5)	8:00pm (4)	7:45am (4)
(N&W) Ar.	10:00pm (5)	9:45am (3)	9:45am (4)	9:45am (3)	9:45am (3)	10:00pm (3)	10:00pm (3)	9:45am (4)	9:45am (4)	9:45am (4)	10:00pm (3)	10:00pm (5)	10:00pm (4)	9:45am (4)
(SLSF) Ar.		12:15pm (3)	12:15pm (4)	12:15pm (3)	12:15pm (3)			12:15pm (4)	12:15pm (4)	12:15pm (4)				12:15pm (4)
(MP) Ar.	11:59pm (5)					11:59pm (3)	11:59pm (3)				11:59pm (3)	11:59pm (5)	11:59pm (4)	
ChicagoCT...(BN) Ar.	1:00pm (6)	11:45pm (3)	11:45pm (4)	11:45pm (3)	11:45pm (3)	1:00pm (4)	1:00pm (4)	11:45pm (4)	11:45pm (4)	11:45pm (4)	1:00pm (4)	1:00pm (6)	1:00pm (5)	11:45pm (4)
(C&NW) Ar.	11:00am (6)	9:00pm (3)	9:00pm (4)	9:00pm (3)	9:00pm (3)	11:00am (4)	11:00am (4)	9:00pm (4)	11:00pm (4)	9:00pm (4)	11:00am (4)	11:00am (6)	11:00am (5)	9:00pm (4)
(CRIP) Ar.	1:30pm (6)					1:30pm (4)	1:30pm (4)				1:30pm (4)	1:30pm (6)	1:30pm (5)	
(IC) Ar.		2:00am (4)	2:00am (5)	2:00am (4)	2:00am (4)			2:00am (5)	2:00am (5)	2:00am (5)				2:00am (5)
(MILW) Ar.	11:00am (6)	11:00pm (3)	11:00pm (4)	11:00pm (3)	11:00pm (3)	11:00am (4)	11:00am (4)	11:00pm (4)	11:00pm (4)	11:00pm (4)	11:00am (4)	11:00am (6)	11:00am (5)	11:00pm (4)
St. LouisCT...(N&W) Ar.	6:00am (6)					9:00pm (3)	6:00am (4)	6:00am (4)	9:00pm (4)	9:00pm (4)	6:00am (4)	6:00am (6)	6:00am (5)	
DecaturCT...(N&W) Ar.	10:00am (6)	7:30am (4)	7:30am (5)	7:30am (4)	7:30am (4)	10:00am (4)	10:00am (4)	7:30am (5)	7:30am (5)	7:30am (5)	10:00am (4)	10:00am (6)	10:00am (5)	7:30am (5)
MemphisCT...(SLSF) Ar.		3:00am (4)	3:00am (5)	3:00am (4)	3:00am (4)			3:00am (5)	3:00am (5)	3:00am (5)				3:00am (5)
(MP) Ar.	12:01am (7)					12:01am (5)	12:01am (5)				12:01am (5)	12:01am (7)	12:01am (6)	

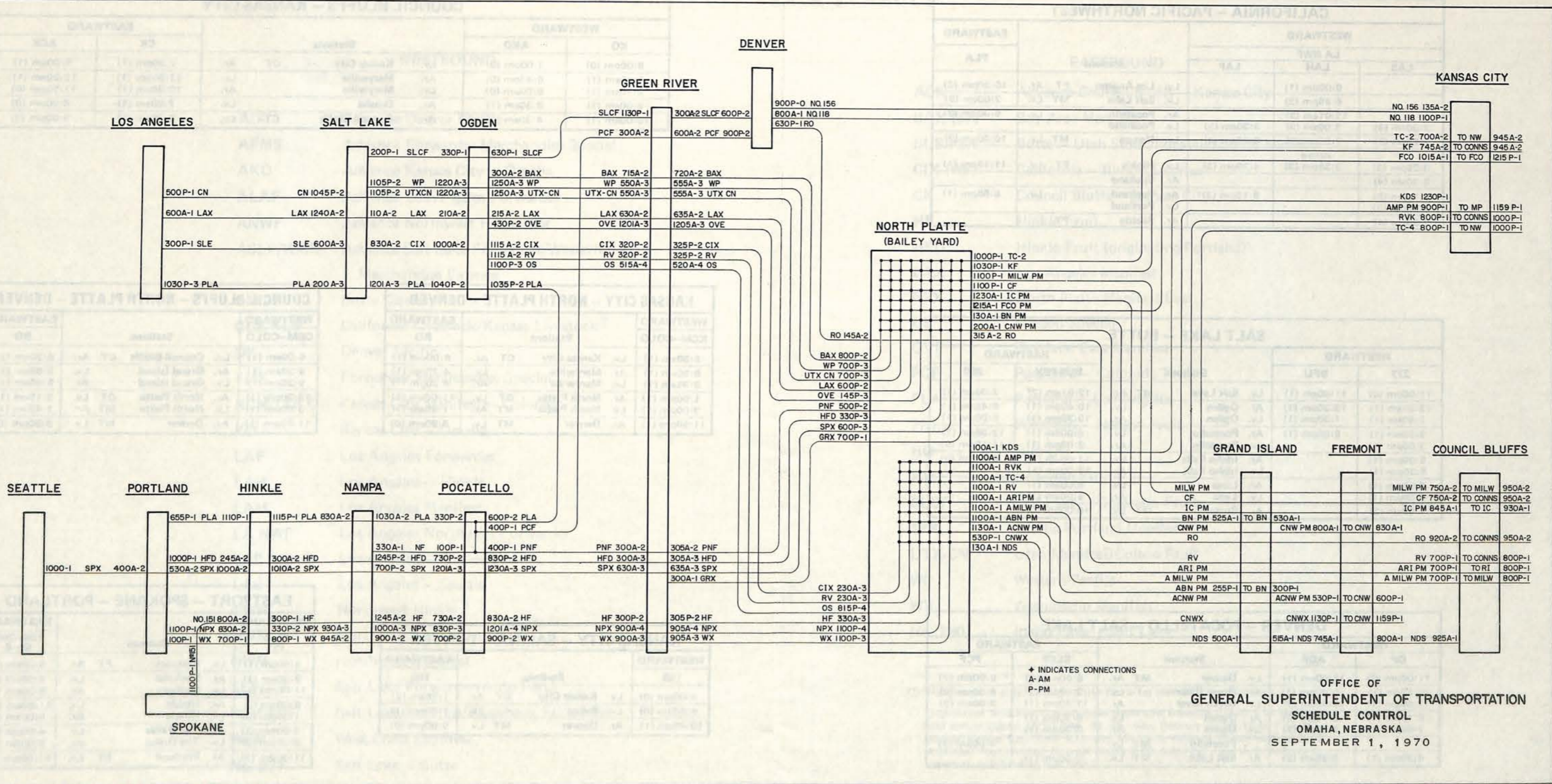

DENVER

GREEN RIVER

KANSAS CITY

LOS ANGELES

SALT LAKE

OGDEN

NORTH PLATTE
(BAILEY YARD)

SEATTLE

PORTLAND

HINKLE

NAMPA

POCATELLO

GRAND ISLAND

FREMONT

COUNCIL BLUFFS

SPOKANE

+ INDICATES CONNECTIONS
A- AM
P- PM

OFFICE OF
GENERAL SUPERINTENDENT OF TRANSPORTATION
SCHEDULE CONTROL
OMAHA, NEBRASKA
SEPTEMBER 1, 1970

CALIFORNIA – PACIFIC NORTHWEST						
WESTWARD			Stations	EASTWARD		
LA NWF				PLA		
LAS	LAH	LAP				
	9:00pm (1)		Lv. Los Angeles	PT	Ar.	10:30pm (3)
	6:45pm (2)		Lv. Salt Lake	MT	Lv.	2:00am (3)
2:30am (3)	12:01am (3) 3:00am (3)	3:30am (3)	Ar. Pocatello Lv. Pocatello		Lv.	6:00pm (2)
7:25am (3)	7:55am (3)	8:25am (3)	Lv. Nampa	MT	Lv.	10:30am (2)
3:25pm (3)	Arrive 3:35pm (3)	4:25pm (3)	Lv. Hinkle	PT	Lv.	11:15pm (1)
5:30am (4)			Ar. Spokane			
8:15pm (3) 8:30pm (3)		9:15pm (3)	Ar. Portland Lv. Portland		Lv.	6:55pm (1)
3:30am (4)			Ar. Seattle	PT		

COUNCIL BLUFFS – KANSAS CITY							
WESTWARD		Stations	EASTWARD				
KO	AKO		CK		ACK		
9:00pm (0)	1:00pm (0)		Lv. Kansas City	CT	Ar.	7:30pm (1)	5:00am (1)
1:45am (1)	6:45pm (0)	Ar. Marysville		Lv.	12:30pm (1)	12:20am (1)	
2:15am (1)	8:00pm (0)	Lv. Marysville		Ar.	10:30am (1)	11:50pm (0)	
9:00am (1)	3:30am (1)	Ar. Omaha		Lv.	7:00am (1)	6:00pm (0)	
10:00am (1)	4:30am (1)	Ar. Council Bluffs	CT	Lv.	6:30am (1)	5:00pm (0)	

SALT LAKE – BUTTE						
WESTWARD		Stations	EASTWARD			
277	BFU		BUS-PSX		280	
11:00pm (0)	11:00am (1)		Lv. Salt Lake	MT	Ar.	12:01am (2)
12:30am (1)	12:30pm (1)	Ar. Ogden		Lv.	10:40pm (1)	5:45am (1)
1:40am (1)	1:30pm (1)	Lv. Ogden		Ar.	10:35pm (1)	5:00am (1)
9:30am (1)	9:00pm (1)	Ar. Pocatello		Lv.	6:00pm (1)	12:05am (1)
3:00pm (1)		Lv. Pocatello		Ar.	2:00pm (1)	11:15pm (0)
5:00pm (1)		Ar. Idaho Falls		Lv.	11:00am (1)	9:00pm (0)
5:30pm (1)		Lv. Idaho Falls		Ar.	10:00am (1)	
8:30pm (1)		Ar. Lima		Lv.	6:00am (1)	
9:30pm (1)		Lv. Lima		Ar.	5:00am (1)	
7:00am (2)		Ar. Butte	MT	Lv.	10:00pm (0)	

KANSAS CITY – NORTH PLATTE – DENVER					
WESTWARD	Stations				EASTWARD
KCM-COLO					RO
5:30am (1)	Lv. Kansas City	CT	Ar.		8:00pm (1)
8:30am (1)	Ar. Marysville		Lv.		4:25pm (1)
8:35am (1)	Lv. Marysville		Ar.		4:20pm (1)
1:50pm (1)	Ar. North Platte	CT	Lv.		11:00am (1)
3:00pm (1)	Lv. North Platte	MT	Ar.		1:45am (1)
11:59pm (1)	Ar. Denver	MT	Lv.		6:30pm (0)

COUNCIL BLUFFS – NORTH PLATTE – DENVER					
WESTWARD	Stations				EASTWARD
CBM-COLO					RO
6:00am (1)	Lv. Council Bluffs	CT	Ar.		9:20am (1)
9:20am (1)	Ar. Grand Island		Lv.		5:55am (1)
9:25am (1)	Lv. Grand Island		Ar.		5:45am (1)
12:30pm (1)	Ar. North Platte	CT	Lv.		3:15am (1)
3:00pm (1)	Lv. North Platte	MT	Ar.		1:45am (1)
11:59pm (1)	Ar. Denver	MT	Lv.		6:30pm (0)

DENVER – POCATELLO – SALT LAKE					
WESTWARD		Stations	EASTWARD		
DP	ADP		SLCF	PCF	
11:00pm (0)	11:00am (1)		Lv. Denver	MT	Ar.
10:30am (1)	10:30pm (1)	Ar. Green River		Lv.	3:00pm (2)
12:30pm (1)	12:30am (2)	Lv. Green River		Ar.	11:30pm (1)
6:15pm (1)	6:15am (2)	Ar. Ogden		Lv.	6:30pm (1)
7:00pm (1)	7:00am (2)	Lv. Ogden		Ar.	3:30pm (1)
		Pocatello	MT	Lv.	
8:25pm (1)	8:25am (2)	Ar. Salt Lake	MT	Lv.	2:00pm (1)

KANSAS CITY – SALINA – DENVER					
WESTWARD	Stations				EASTWARD
155					156
4:00pm (0)	Lv. Kansas City	CT	Ar.		1:35am (2)
8:50pm (0)	Lv. Salina		Lv.		7:00pm (1)
10:45am (1)	Ar. Denver	MT	Lv.		9:00pm (0)

EASTPORT – SPOKANE – PORTLAND					
WESTWARD	Stations				EASTWARD
SI-9 151					198-298 SI-8
4:00am (1)	Lv. Eastport	PT	Ar.		3:00am (2)
9:00am (1)	Ar. Spokane		Lv.		9:00pm (1)
11:00pm (1)	Lv. Spokane		Ar.		8:00pm (1)
8:00am (2)	Ar. Hinkle		Lv.		11:00am (1)
1:30pm (2)	Lv. Hinkle		Ar.		8:00am (1)
5:00pm (2)	Ar. The Dalles		Lv.		4:00am (1)
6:00pm (2)	Lv. The Dalles		Ar.		3:00am (1)
11:00pm (2)	Ar. Portland	PT	Lv.		11:00pm (0)

MANIFEST TRAIN SYMBOLS

WESTBOUND

ADP	Advance Denver Pacific
AFMS	Advance Forwarder Merchandise Special
AKO	Advance Kansas City – Omaha
ALAF	Advance Los Angeles Forwarder
ANWF	Advance Northwest Forwarder
ASLF/WMX	Advance Salt Lake Forwarder/Western Merchandise Express
BFU	Butte Cleanup
CLS/KLS	California Livestock/Kansas Livestock ^①
DP	Denver Pacific
FMS	Forwarder Merchandise Special
KCM/COLO	Kansas City Manifest – Colorado
KO	Kansas City – Omaha
LAF	Los Angeles Forwarder
LAH	Los Angeles – Hinkle
LAM	Los Angeles Manifest
LA NWF	Los Angeles Northwest Forwarder
LAP	Los Angeles – Portland
LAS	Los Angeles – Seattle
NWH	Northwest Hinkle
NWF	Northwest Forwarder
NWM	Northwest Manifest
SLF/AP	Salt Lake Forwarder/Auto Parts
SLM/PBF	Salt Lake Manifest/Piggyback Forwarder
WCM	West Coast Manifest
No. 277	Salt Lake – Butte

EASTBOUND

ACK	Advance Council Bluffs – Kansas City
BAX (SP)	Bay Area Manifest
BUS/PSX	Butte – Utah Stock/Pocatello South Manifest
CIX (WP)	California – Illinois Express
CK	Council Bluffs – Kansas City
HF	Hinkle Fruit
HFD	Hinkle Fruit (originating Portland)
LAX	Los Angeles Manifest
NPX	North Platte Manifest East
OS	Oregon Special
OVE	Overland East Manifest
PCF	Pocatello – Colorado Fruit
PLA	Portland – Los Angeles
PNF	Pocatello – Nampa Fruit
RO	Run-Off
RV	Roseville Fruit ^②
SLCF	Salt Lake – Colorado Fruit
SPX	Seattle Portland Manifest
UTX-CN	Utah Manifest/Colton Fruit
WP	Western Pacific
WX	Washington Manifest
No. 280	Idaho Falls – Salt Lake

① Handles stock only, through North Platte for West Coast destinations.

② Guaranteed schedule contemplates departure Roseville 10:00 P.M. day one and arrival Ogden 10:50 P.M. PT day two. Delivery cutoff 11:50 P.M. MT. Arrival Kansas City 7:45 A.M. day four with delivery to connections 9:45 A.M. day four. Arrival Council Bluffs 7:50 A.M. day four with delivery to connections 9:50 A.M. day four.